



FPZ, Inc
 150 N. Progress Drive
 Saukville, WI 53080 - U.S.A.
 Tel. (262) 268-0180
 Fax (262) 268-0415
 E-mail usa@fpz.com

REGENERATIVE BLOWERS - VACUUM
SCL 20DH / 30DH / 40DH

DH SERIES
 SN 2465-1 1/2

STANDARD FEATURES

- Low weight cast aluminum construction.
- Quiet operation with integral inlet and outlet muffling.
- Recognized TEFC - **cURus** motor.
- High efficiency / low noise impeller design.
- No lubrication / maintenance required.
- Allowed ambient: +5 °F to +104 °F.
- Mountable in any plane.

OPTIONS

- Remote drive models (belt or coupling).
- Special voltages.
- Surface treatment or plating.
- Gas tight sealing.
- Special designs available.

ACCESSORIES

- Inlet and/or inline filters.
- Additional inlet/outlet silencers.
- Safety valves.
- Flow converting devices.
- Optional connectors

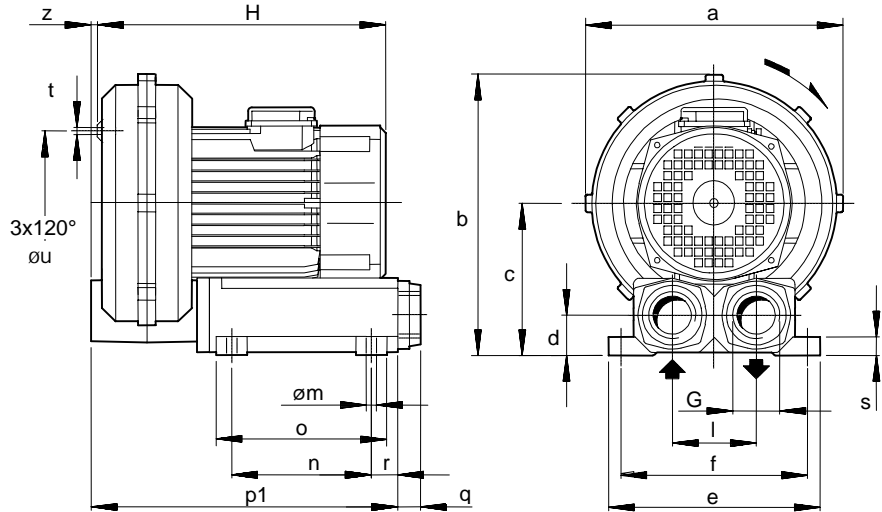

Dimensions in inches.
 Dimension for reference only.

Model	a	b	c	d	e	f	G	l	m	n	o	p1	q	r	s	t	u	z
20DH	11.42	12.20	6.50	1.77	9.06	8.27	1" ¼ NPT	3.54	0.39	5.90	7.67	13.98	0.71	1.77	0.79	M6	5.91	0.31
30DH	12.60	13.66	7.36	2.09	10.63	9.64	1" ½ NPT	4.13	0.39	7.28	9.25	16.54	0.71	2.17	0.79	M6	7.09	0.67
40DH	13.78	14.57	7.68	2.09	10.63	9.65	1" ½ NPT	4.13	0.39	7.28	9.25	17.32	0.71	2.17	0.79	M8	8.86	-

Model	Maximum flow cfm		Installed power Hp		Maximum differential pressure Δp (In Hg)		Noise level Lp dB (A) ⁽¹⁾		Overall dimensions H Inches	Weight Lbs
	60 Hz 3500 rpm	50 Hz 2900 rpm	60 Hz 3500 rpm	50 Hz 2900 rpm	60 Hz 3500 rpm	50 Hz 2900 rpm	60 Hz 3500 rpm	50 Hz 2900 rpm		
20DH	48	42	1	1	6.2	6.9	67.7	64.7	13.78	44.00
			1 ½	1 ½	8.1	7.4	68.0	65.0		
30DH	70	61	2	2	10.3	8.9	69.7	67.7	15.36	58.30
40DH	98	85	3	3	11.1	10.3	74.7	71.7	16.93	75.00

(1) Noise measured at 1 m distance with inlet and outlet ports piped, in accordance to ISO 3744.

- For proper use, the blower should be equipped with inlet filter and safety valve; other accessories available on request.
- Ambient temperature from +5° to +104°F.
- Specifications subject to change without notice.

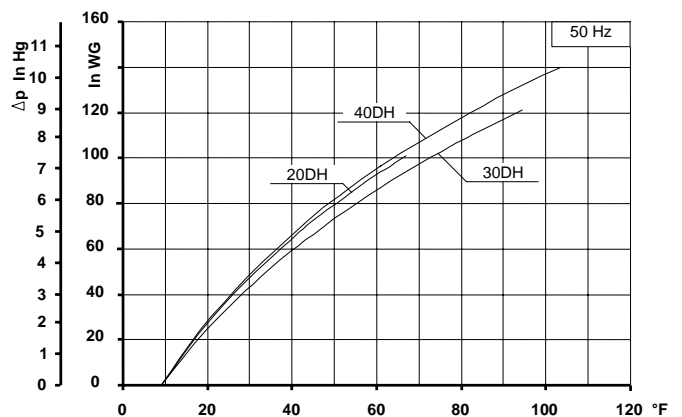
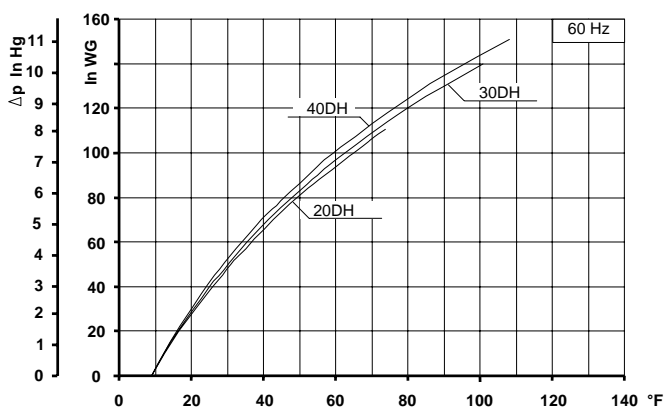
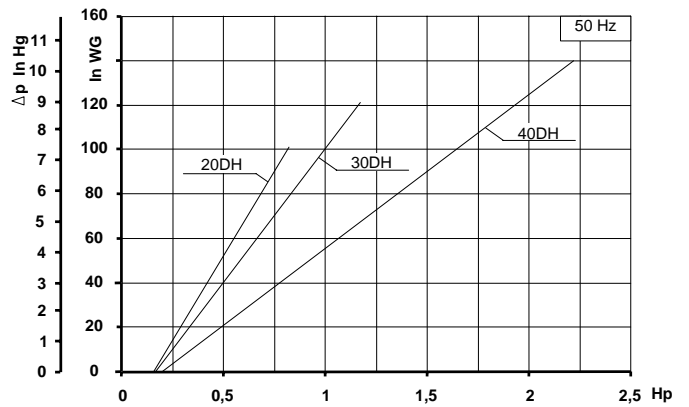
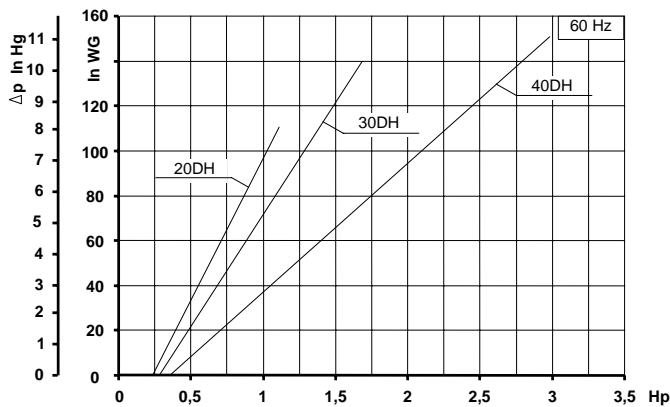
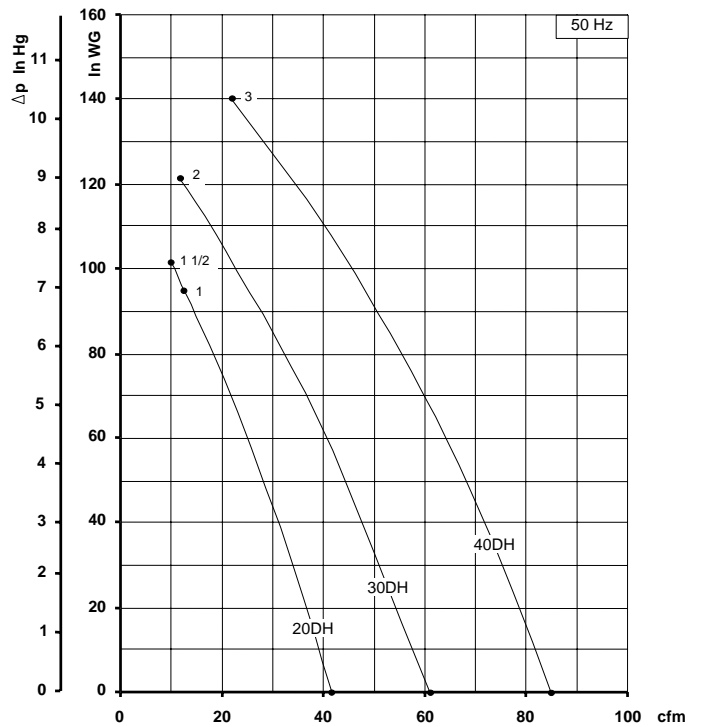
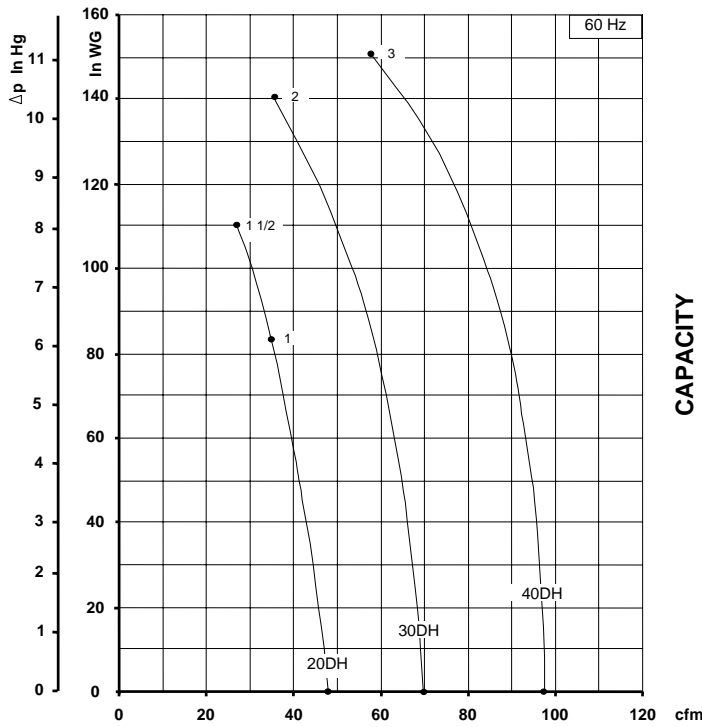

Curves refer to air at 68° F temperature, measured at inlet port and 29.92 In Hg atmospheric backpressure (abs).
 Values for flow, power consumption and temperature rise: +/-10% tolerance.
 Data subject to change without notice.