



TECHNICAL CHARACTERISTICS

- Aluminium alloy construction
- Smooth operation
- High efficiency impeller
- Maintenance free
- Mountable in any position
- G1/8" female thread on both suction and discharge silencer port flanges

OPTIONS

- Special voltages (IEC 38)
- Surface treatments

Possible alternative positions, please refer to drw SI 1826

Dimensions in mm.
 Dimensions for reference only

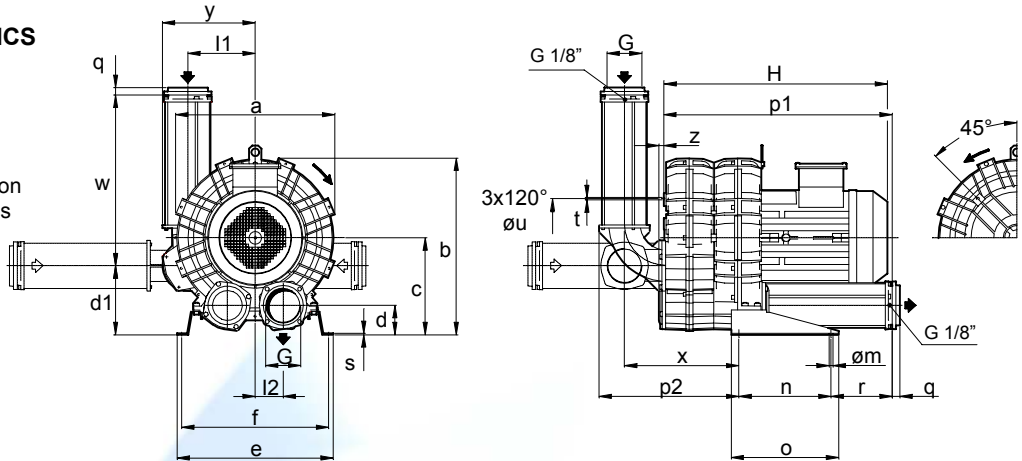

Model	a	b	c	d	d1	e	f	G	l1	l2	m	n	o	p1	p2	q	r	s	t	u	w	x	y	z
K07-TD	424	481	269	82	192	468	438	G 3"	187	77.5	13	300	350	649	392	25	137	5	M8	295	481	319	260	16
K08-TD	457	498	269	82	192	478	448	G 3"	187	77.5	13	300	350	649	392	25	137	5	M8	310	481	319	260	16
K09-TD	492	561	315	96	225	508	478	G 4"	220	91	13	300	350	745	455	25	199	5	M8	360	556	372	302	16
K10-TD	516	573	315	96	225	508	478	G 4"	220	91	13	300	350	745	455	25	199	5	M8	360	556	372	302	16
K11-TD	542	602	332	90	232	538	508	G 4"	242	100	13	300	350	765	470	25	204	5	M8	390	556	387	324	16

Model	Maximum flow m³/h		Installed power kW		Maximum differential pressure Δp hPa (mbar)		Noise Level Lp dB (A) (1)		Overall dimensions H mm	Weight Kg
	50 Hz 2900 rpm	60 Hz 3500 rpm	50 Hz 2900 rpm	60 Hz 3500 rpm	50 Hz 2900 rpm	60 Hz 3500 rpm	50 Hz 2900 rpm	60 Hz 3500 rpm		
	K07-TD	417	503	5.5	6.3	325	275	76.6	78.6	585
			7.5	8.7	425	410	76.9	78.9	620	90.0
			-	10.6	-	450	-	79.2	620	99.5
K08-TD	518	625	5.5	6.3	235	180	77.0	79.0	585	90.5
			7.5	8.7	350	290	77.3	79.3	620	95.5
			9.2	10.6	450	390	77.6	79.6	620	105.0
			-	12.7	-	475	-	79.9	620	105.5
K09-TD	657	793	9.2	10.6	300	240	79.9	81.9	650	115.5
			11.0	12.7	390	320	80.2	82.2	650	116.0
			15.0	17.4	450	475	80.5	82.5	650	130.0
K10-TD	804	971	11.0	12.7	325	275	83.9	85.9	650	124.0
			15.0	17.4	450	375	84.2	86.2	650	138.0
			18.5	21.5	500	500	84.5	86.5	745	165.0
K11-TD	903	1090	11.0	12.7	235	160	84.2	86.2	665	131.0
			15.0	17.4	375	280	84.7	86.7	665	145.0
			18.5	21.5	450	400	85.2	87.2	760	172.0

(1) Noise measured at 1 m distance with inlet and outlet ports piped, in accordance to ISO 3744.

- For proper use, the blower should be equipped with inlet filter and safety valve; other accessories available on request.
- Ambient temperature from -15° to +40°C.
- Specifications subject to change without notice.



ATERAL CHANNEL BLOWERS - EXHAUSTERS
SCL K07 / K08 / K09 / K10 / K11
TD SERIE - MOR RANGE
 SN 1831-8 2/2

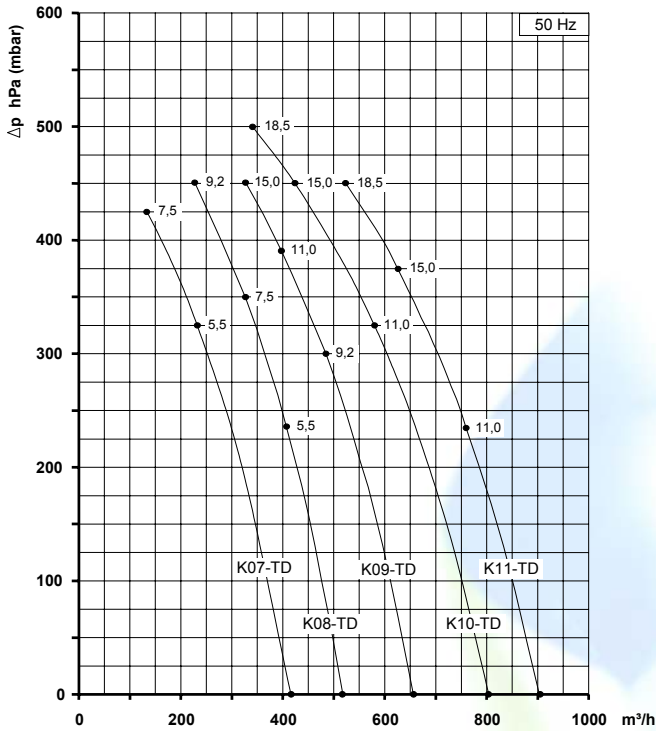

CAPACITY

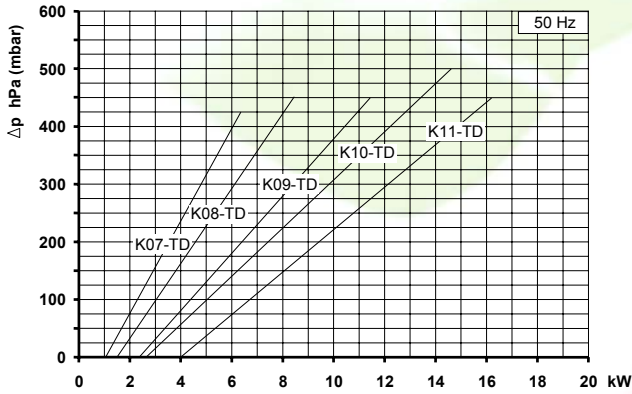
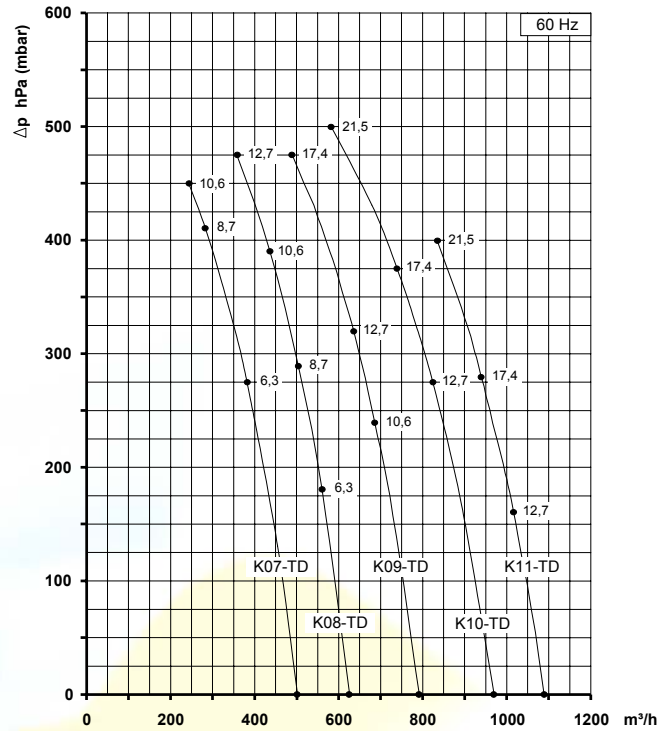

ABSORBED POWER

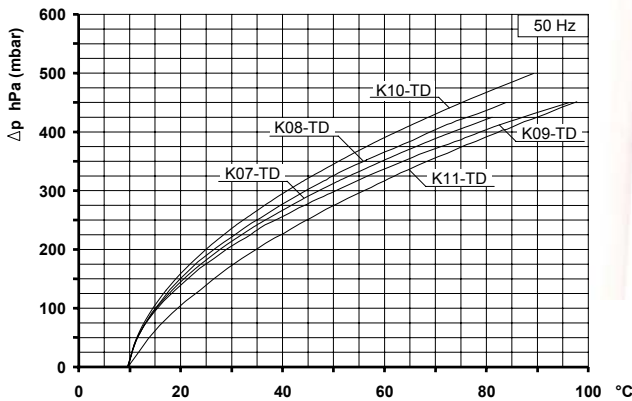
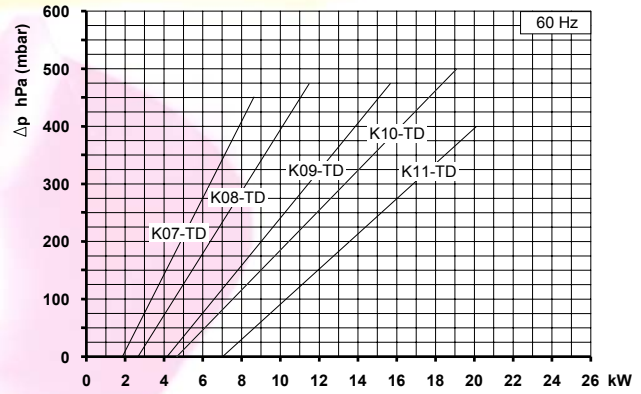

TEMPERATURE INCREASE

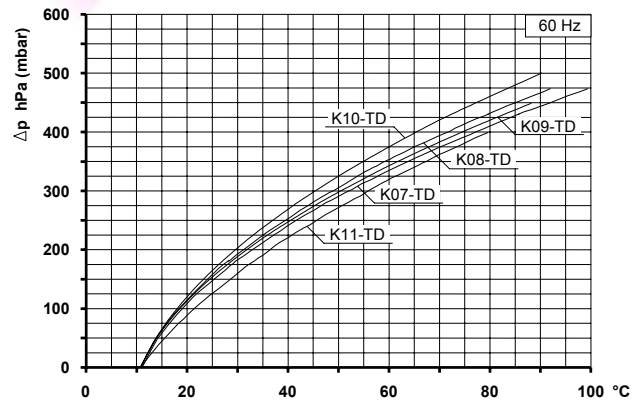

Curves refer to air at 20°C temperature, measured at inlet port and 1013 mbar (abs) atmospheric backpressure.
 Tolerance on given values: ±10%.
 Data can change without prior notice.