



FPZ, Inc
 150 N. Progress Drive
 Saukville, WI 53080 - U.S.A.
 Tel. (262) 268-0180
 Fax (262) 268-0415
 E-mail usa@fpz.com

REGENERATIVE BLOWERS - PRESSURE

SCL 115SH
GOR / GVR RANGE
 SN 2224-1 1/2

STANDARD FEATURES

- Low weight cast aluminum impeller and cast iron casing.
- Quiet operation with integral inlet and outlet muffling.
- Recognized TEFC motor.
- High efficiency / low noise impeller design.
- No lubrication / maintenance required.
- Allowed ambient: +5 °F to +104 °F.
- Mountable in any plane.

OPTIONS

- Special voltages.
- Surface treatment or plating.
- Gas tight sealing.
- Special designs available.

ACCESSORIES

- Inlet and/or inline filters.
- Additional inlet/outlet silencers.
- Safety valves.
- Flow converting devices.
- Optional connectors

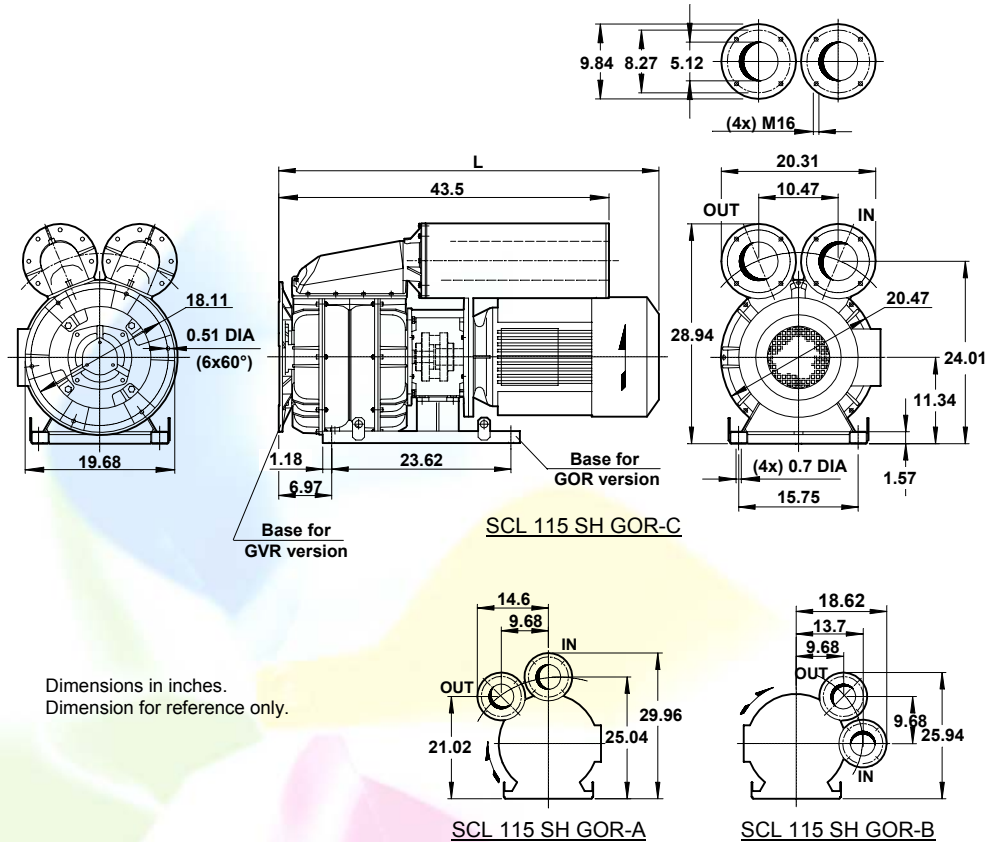

Dimensions in inches.
 Dimension for reference only.

Model	Maximum flow Scfm		Installed power Hp		Maximum differential pressure Δp (In WG)		Noise level Lp dB (A) ⁽¹⁾		Overall dimensions H Inches	Weight Lbs ⁽²⁾	
	60 Hz 3500 rpm	50 Hz 2900 rpm	60 Hz 3500 rpm	50 Hz 2900 rpm	60 Hz 3500 rpm	50 Hz 2900 rpm	60 Hz 3500 rpm	50 Hz 2900 rpm		GOR	GVR
115SH	1530	1265	-	15	-	40	-	93.8	47.25	500	440
			20	20	40	60	96.8	94.1	47.25	500	440
			25	25	60	80	97.1	94.4	47.25	500	440
			30	30	80	100	97.4	94.7	49.41	500	440
			40	40	110	160	97.7	95.0	50.78	502	442
			50	-	140	-	98.0	-	51.77	502	442

(1) Noise measured at 1 m distance with inlet and outlet ports piped, in accordance to ISO 3744.
 (2) Value is referred to weight of the machine without electric motor.

- For proper use, the blower should be equipped with inlet filter and safety valve; other accessories available on request.
 - Ambient temperature from +5° to +104°F.
 - Specifications subject to change without notice.

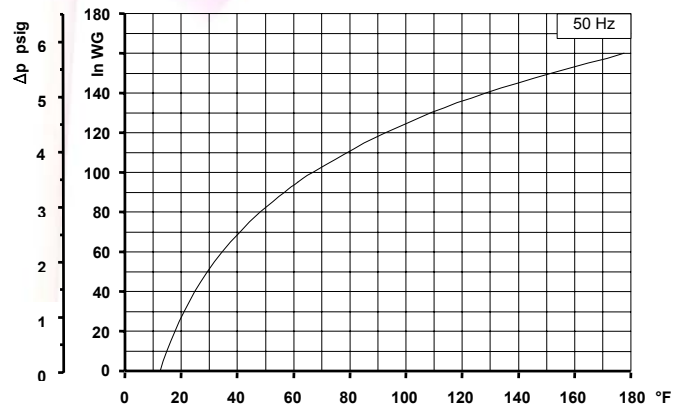
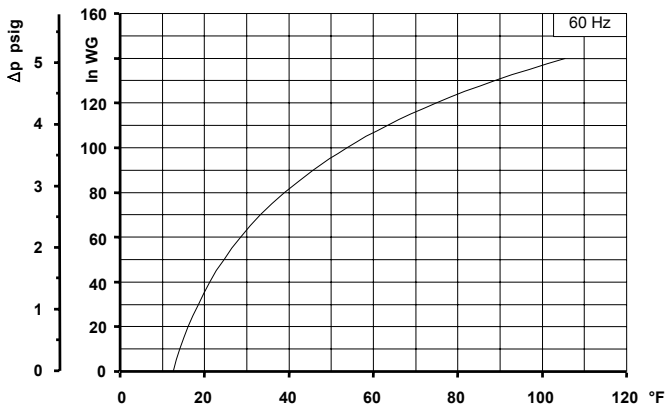
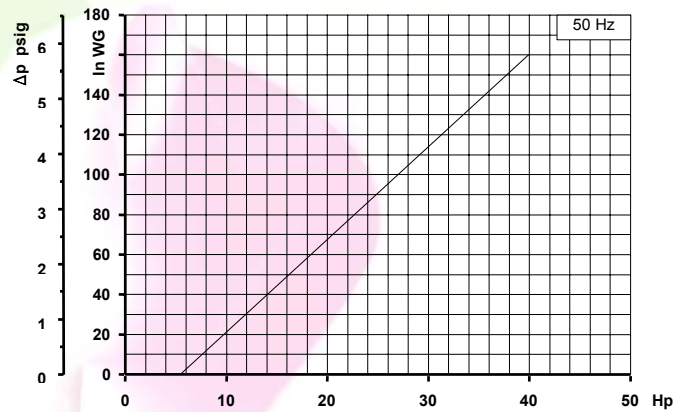
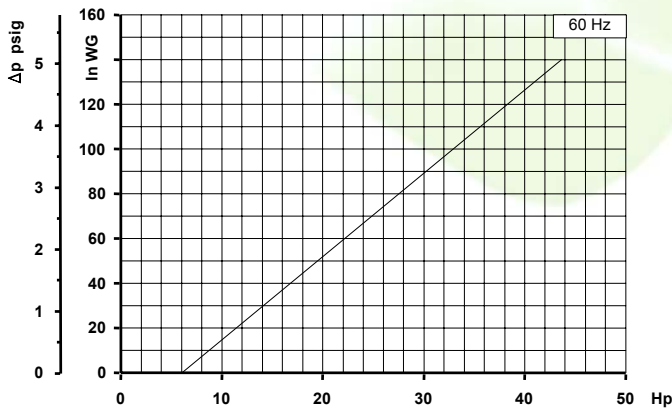
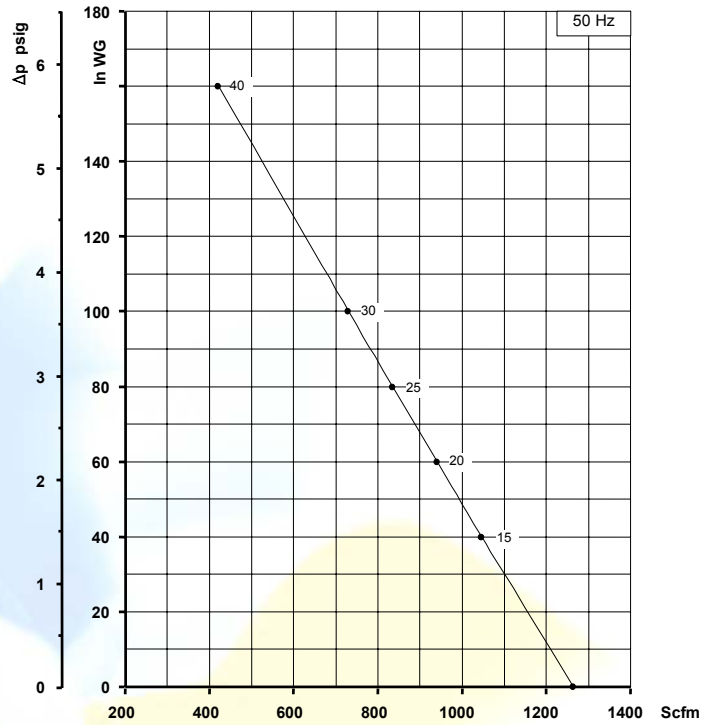
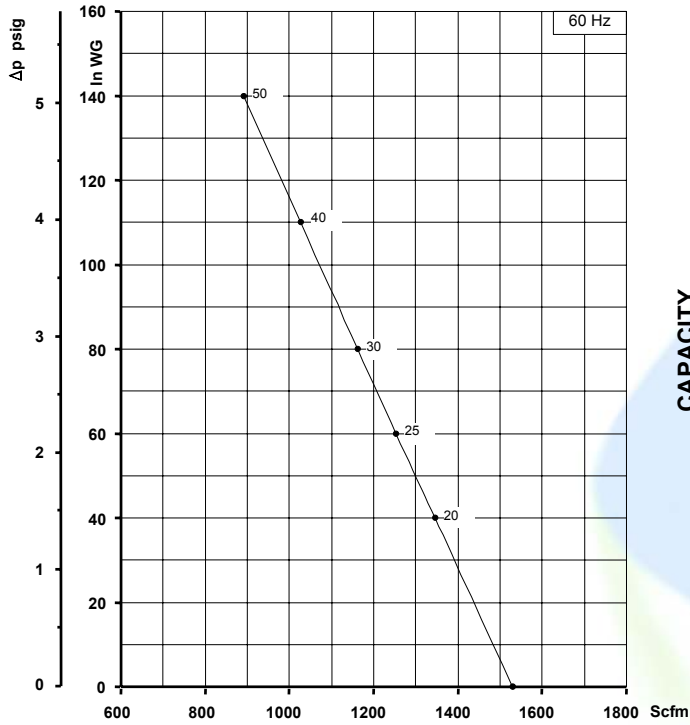

Curves refer to air at 68°F temperature and 29.92 In Hg atmospheric pressure (abs) measured at inlet port.
 Values for flow, power consumption and temperature rise: +/-10% tolerance.
 Data subject to change without notice.