

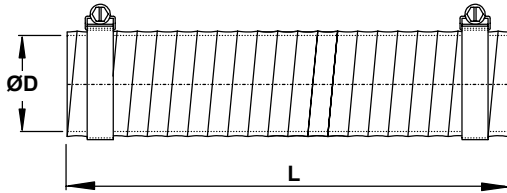

FLEXIBLE SLEEVE

Steel reinforced rubber - coated fibreglass flex tubing, including 2 adjustable hose clamps. Working temperature: -55 ÷ +176 °C (-67 ÷ +350 °F). Maximum working pressure: 3 bar (44 psi).



TYPE	DN	D	L
MF 1	1/2"	20	200
MF 2	3/4"	26	
MF 3	1"	32	
MF 4	1" 1/4	45	250
MF 5	1" 1/2	50	
MF 6	2"	64	330
MF 8	3"	89	
MF 9	4"	114	
MF 10	5"	140	

THREADED FLANGE

Threadened flange in aluminum alloy.

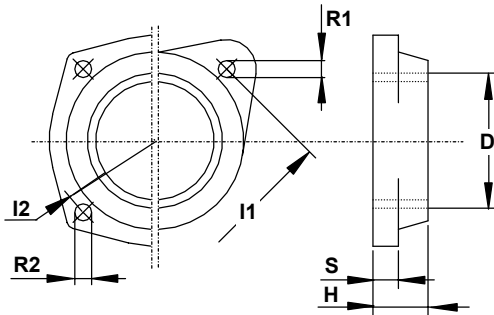

TYPE	D	H	I 1	I 2	R 1	R 2	S
TF 3	G 1"	18	55	-	6.5	-	10
TF 4	G 1" 1/4		75				
TF 4V			64				
TF 5	G 1" 1/2		85				
TF 5V		75					
TF 6	G 2"	25	-	120	-	6.5	13
TF 8	G 3"			150		9	
TF 9	G 4"			210		17	
TF 10	G 5"	35	-	-	-	-	-

SLEEVE

Aluminum alloy or steel flanged sleeve coupling.

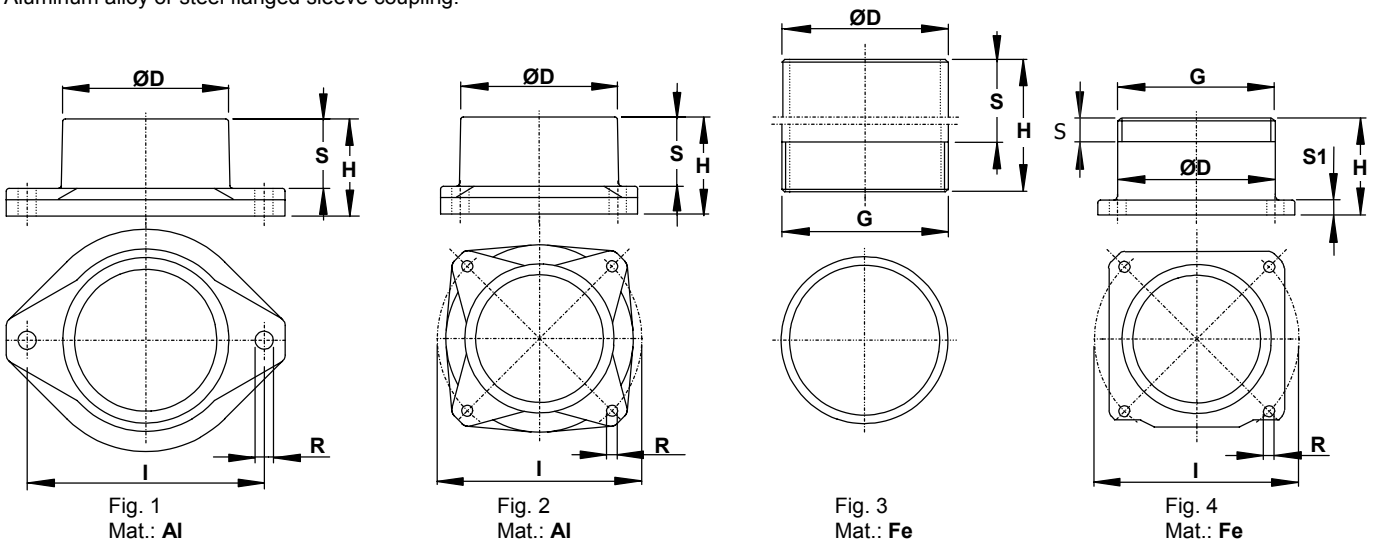

Dimensions in mm.

TYPE	DN	D	G	H	I	R	S	Fig.
MP 1	1/2"	21	G 1/2"	100	-	-	85	3
MP 2	3/4"	27	G 3/4"					
MP 3	1"	33	-	35	55	6.5	25	1
MP 4	1" 1/4	42			75			
MP 4V					64			
MP 5	1" 1/2	48			85			
MP 5V					75			

TYPE	DN	D	G	H	I	R	S	S1	Fig.
MP 6	2"	60	-	35	85	6.5	25	-	1
MP 8	3"	88		45	120		32		2
MP 9	4"	114	G 4"	100	-	-	80	-	3
MP 10	5"	140	-	60	210	17	-	8	4
MP 10G			G 5"				30		
MP 10N			5" NPT						